

Installation Instruction Repair Clamp RS-2

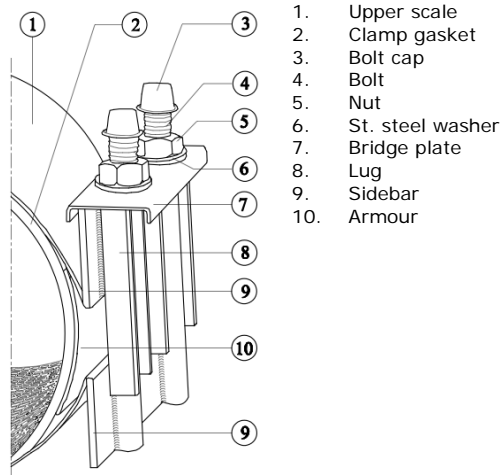

IMPORTANT: Always check that you have a correct and fully functional product before you start any excavations or repairs. When in doubt, take a spare unit with you to avoid delaying the work.

Before installation:

1. Check the diameter of the pipe and make sure you are using correctly sized clamps.
2. Clean the pipe to remove as much dirt and corrosion as possible from the surface. Scrape the pipe to remove dirt and corrosion so that the surface is smooth.
3. Make sure no foreign material sticks to the gasket as it is wrapped around the pipe, nor becomes lodged between gasket and pipe as the nuts are tightened.
4. Keep threads free of foreign material to facilitate tightening.
5. Use a torque wrench to achieve proper torque. Also make sure you use the right wrench size (step 5).
6. Bolts are often not sufficiently tightened if a torque wrench is not used. Take extra care in this situation to ensure proper tightening.

Installation:

Step 1

Mark the pipe where the ends of the clamp will be. After installation use this mark to confirm that the clamp has been properly positioned.

Step 2

Thoroughly clean the pipe surface area to be covered by the clamp. Apply lubricant to pipe and rubber inside the clamp to ensure a proper seal. **DO NOT use grease!**

Step 3

Back off nuts to end of bolts, but **DO NOT REMOVE THEM**. Open up the clamp and put the upper scale on the pipe. (Fig. 1). At one side the bridge plate of the underscale has to be suspended over the lugs. Hinge the suspended underscale under the pipe (Fig. 2).

Note: If necessary (because of excessive leakage) steps 3 and 4 can be performed beside the pipe fracture or damage. Then slide the clamp over the fracture after snapping the bridge plate onto the lugs.

Step 4

Snap the bridge plate OVER the lugs (Fig. 3). Do not use force. Be sure that the armour slides under the scale and that the gasket tails are not folded under, but are lying flat around the pipe. Pull the bridge plates towards each other and tighten the nuts by hand first.

Step 5

Then use a torque wrench with a handle of at least 300 mm in length (Fig. 4) to tighten the nuts evenly in 20 Nm increments and in the specified order (Fig. 5).

Wrench size:

| Recommended torque | M12: 65 Nm | 19 |
|--------------------|-------------|----|
| | M14: 85 Nm | 22 |
| | M16: 110 Nm | 24 |

Always pressure test for leaks before backfilling the ditch. If leakage occurs repeat step 3, 4 & 5. Then pressure test again.

Step 6

Wait 20 minutes and then retighten to proper torque. Backfill and compact carefully around clamp.

Note: When installed on plastic pipes, please contact your supplier.

All our quotations, all orders placed with us and all contracts concluded with us are subject to the METAALUNIECONDITIONS, filed with the registrar of the District Court of Rotterdam, as stipulated in the latest text lodged with the said Court. The conditions of delivery and payment have been sent to you earlier and are in your possession, but if they are not, they will be sent to you again upon request. All agreements are subject to the law of the Netherlands.

All disputes arising from offers and agreements, however such disputes may be called, shall be submitted to the competent Dutch Court.

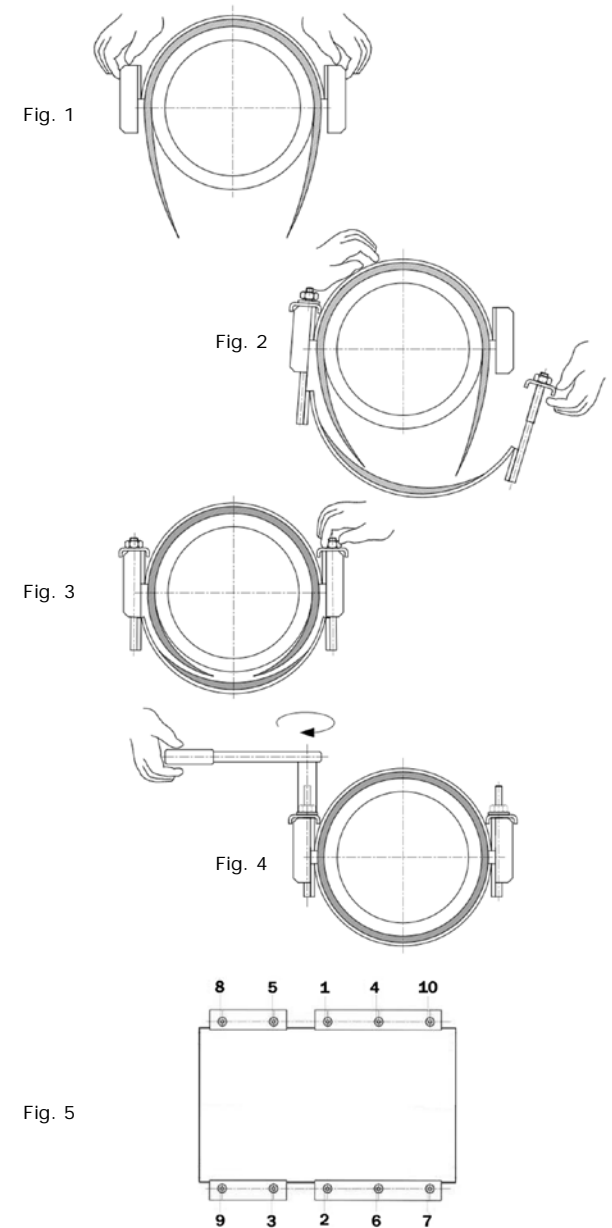

ROMACON